

Immersion Pumps STA401...409

Semi-open impellers



Hoogeindsestraat 5
NL - 5447 PD Rijkevoort
Nederland
T : +31 (0) 485 - 371318
F : +31 (0) 485 - 371918
info@pompentechniek.nl
www.pompentechniek.nl



STA401...409

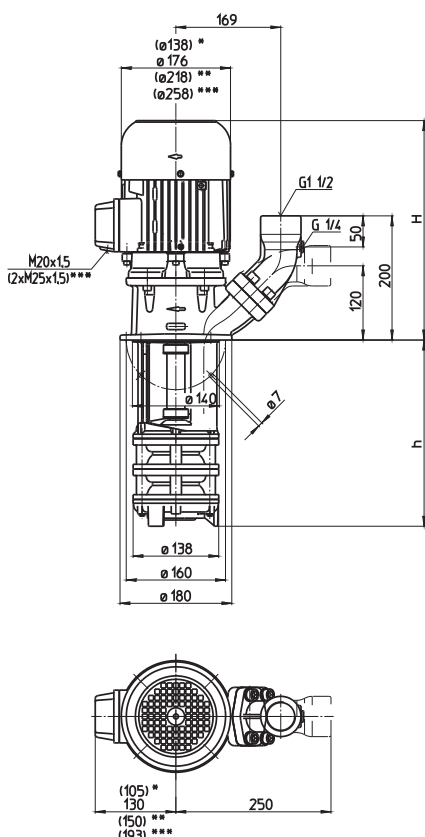

- *) Dimensions for STA401
- **) Dimensions for STA406, 407
- ***) Dimensions for STA409

Type	Vol. del. at manom. del. head l/min /m	Height H mm	Depth of im- mersion h mm	Weight kg	Power kW	Voltage 3 ~ V	Fre- quen- cy Hz	Current A	Speed 1/min
STA401/120	250/5	311	120	15	0.85	220-240	50	4.3	2800
200			200	16		380-420	50	2.5	2800
270			270	17		460	60	2.5	3300
350			350	18					
440			440	19					
550			550	20					
750			750	22					
900			900	23					
STA402/170	250/12	355	170	30	1.3	220-240	50	5.2	2850
250			250	31		380-420	50	3.0	2850
320			320	32		460	60	3.0	3400
400			400	33					
490			490	34					
600			600	35					
800			800	37					
950			950	38					
STA403/220	250/20	355	220	32	1.7	220-240	50	7.1	2850
300			300	33		380-420	50	4.1	2850
370			370	34		460	60	4.1	3400
450			450	35					
540			540	36					
650			650	37					
850			850	39					
1000			1000	40					
STA404/270	250/27	395	270	38	2.2	220-240	50	9.2	2850
350			350	39		380-420	50	5.3	2850
420			420	40		460	60	5.3	3400
500			500	41					
590			590	42					
700			700	43					
900			900	45					
1050			1050	46					
STA405/320	250/33	405	320	42	2.6	220-240	50	10.9	2850
400			400	43		380-420	50	6.3	2850
470			470	44		460	60	6.3	3400
550			550	45					
640			640	46					
750			750	47					
950			950	49					
1100			1100	50					
STA406/370	250/39	445	370	55	3.3	220-240	50	13.8	2900
450			450	56		380-420	50	8.0	2900
520			520	57		460	60	8.0	3450
600			600	58					
690			690	59					
800			800	60					
1000			1000	61					
STA407/420	250/45	445	420	59	4.0	220-240	50	16.5	2900
500			500	60		380-420	50	9.5	2900
570			570	61		460	60	9.5	3450
650			650	62					
740			740	63					
850			850	64					
STA409/520	250/52	480	520	80	5.5	220-240	50	22.0	2900
600			600	81		380-420	50	12.5	2900
670			670	82		460	60	12.5	3450
750			750	83					
840			840	84					
950			950	85					

Immersion Pumps

are plain centrifugal pumps with the impeller fitted on the driving shaft extension. They are mounted on top of the container, the pump extension being immersed in the coolant.

The maximum coolant level must stay a few mm/inches below the mounting flange.

The STA serie offers a (SAE) flange with pressure gauge connection port.

The flange can be rotated for either horizontal or vertical pipe connections.



All types are also available as quick-suctioning immersion pumps equipped with "BRINKMANN's Suction De-aeration System". See series SAL.



All types are also available as suction immersion pump with a connection to the vacuum filters on the suction side. See series STS.



Applications

- Types of fluid
 - coolants
 - cooling/cutting oils
- Kinematic viscosity
 - ...90 mm²/s (90 cSt)
- Pumping temperature
 - 0...80° C
 - higher temperatures upon request

Construction

Pump body	cast iron
Cover	cast iron
Impellers	brass
Shaft	steel
Optional:	
Suction cover	with threaded inlet
Impellers	cast steel
Noise level	
STA401	62 dBA
STA402...STA405	66 dBA
STA406...STA409	71 dBA

